

n.4 fori passanti per viti UNI5931

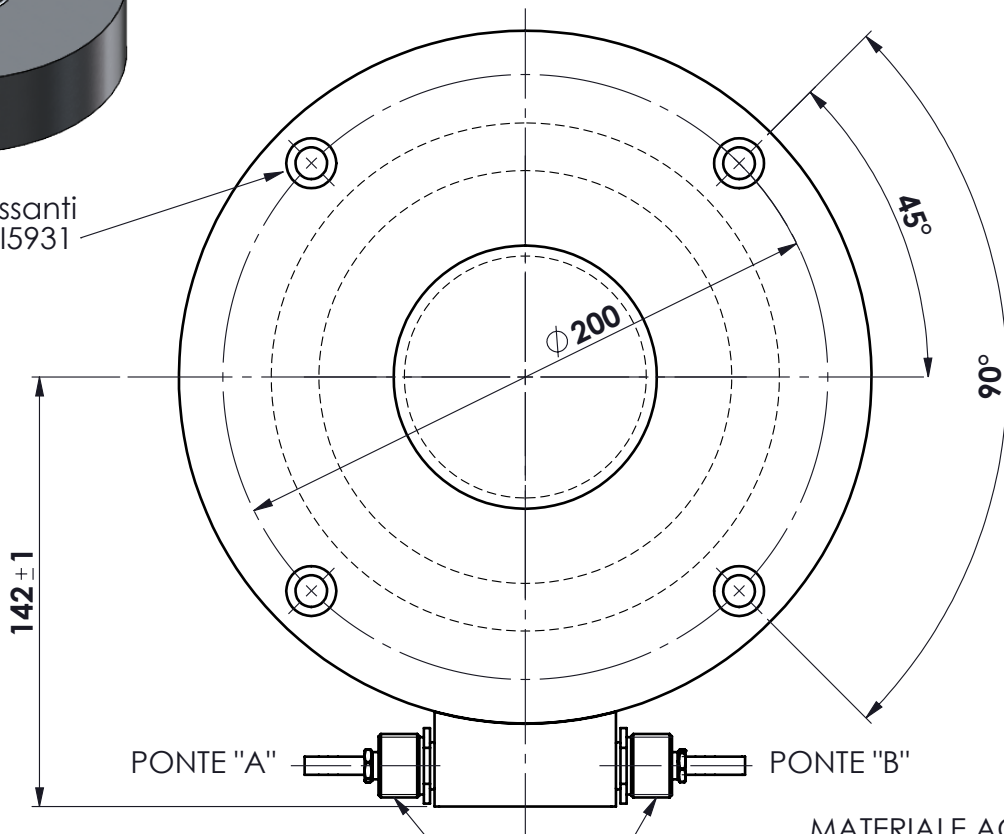

MATERIALE ACCIAIO INOX
 PORTATA kg. 200.000
 SENSIBILITA' 2 mV/V
 Protezione IP68

Presse-étoupe 1/2" GAS Special et m. 50
 de câbles de sortie avec la tresse métallique
 fourni par Scaime

toler. gen.	0 ÷ 30	±0.10
	30 ÷ 100	±0.15
	100 ÷ 300	±0.25
	300 ÷ 500	±0.50
	foro/alb H9 - h9	
	sm. e raggi	0.5

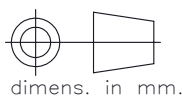

peso kg. 20.19
 Data 19.01.2017
 Scala 1:2.5

CELLA IN COMPRESSIONE
 mod. CMF 200.000 DOP
 ASSIEME

N° DISEGNO A.1682

foglio 1
 di 1

disegnato MR

controllato

MATERIALE

GREZZO

TRATTAMENTO

FINITURA LAVORAZ.



METIOR s.r.l.