

Pressacavo M8
cavo m. 5
mod. SLS-0140

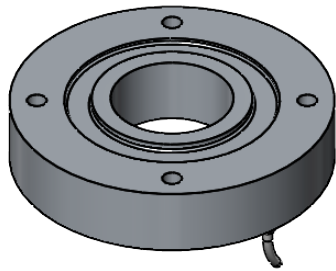

MATERIALE ACCIAIO INOX
PORTATA 5.500 kg.
SENSIBILITA' 2 mV/V
protezione IP67

toler. gen.	0 ÷ 30	±0.10
	30 ÷ 100	±0.15
	100 ÷ 300	±0.25
	300 ÷ 500	±0.50
foro/alb	H9	- h9
sm. e raggi		0.5

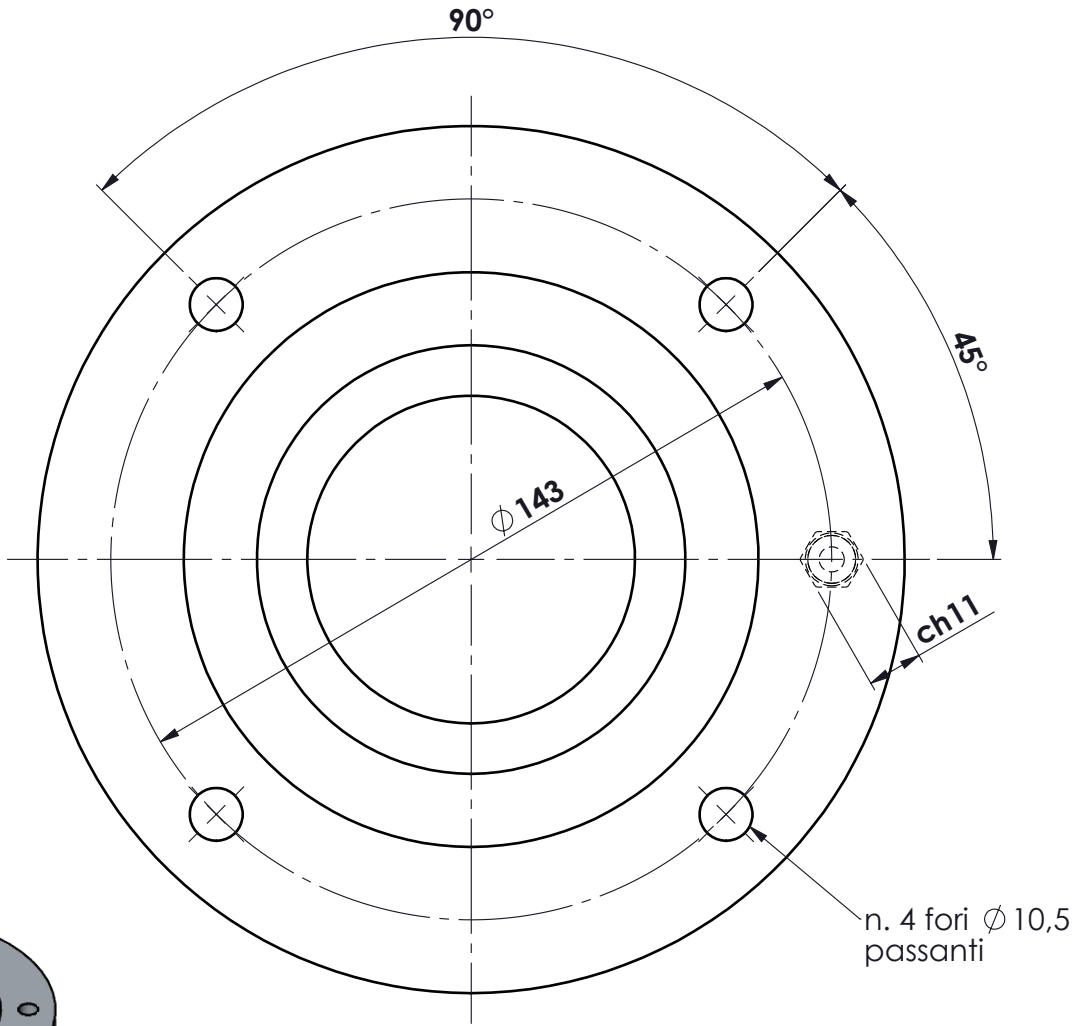
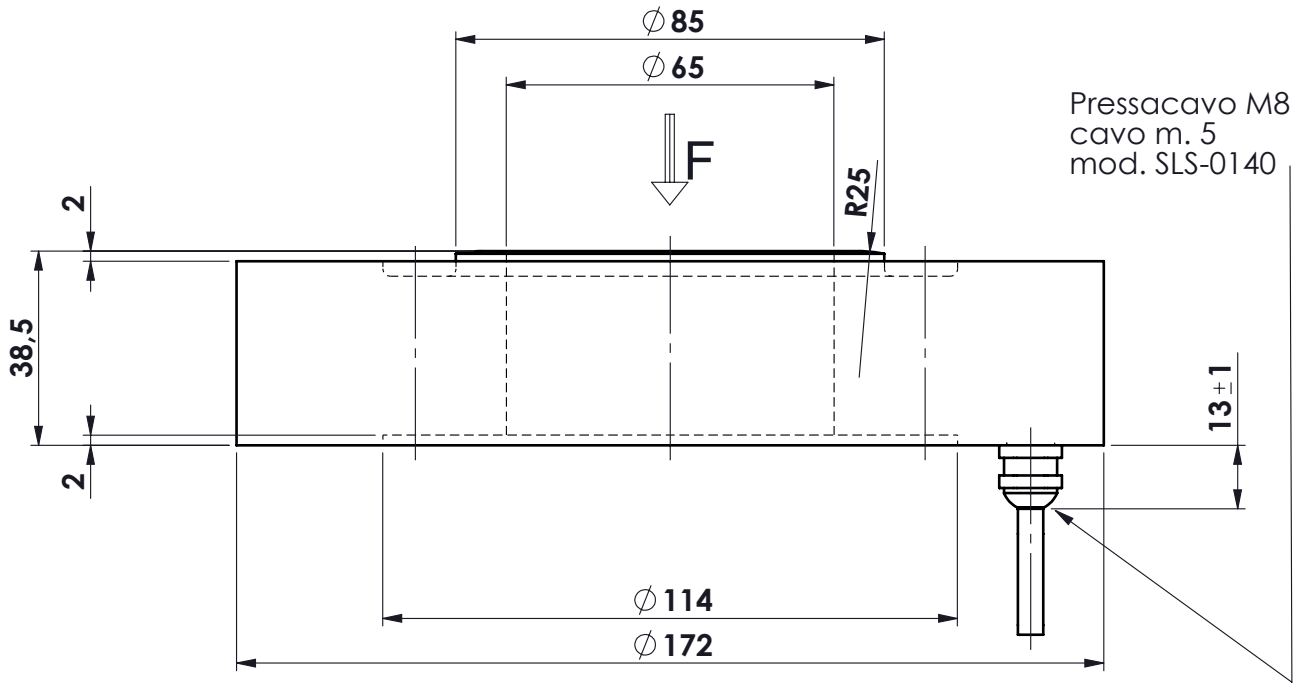
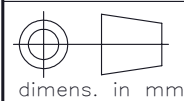

peso kg. 5.53
Data 12.03.2018
Scala 1:1.5

CELLA DI CARICO IN COMPRESSIONE
mod. CRQ 5500
ASSIEME CELLA

N° DISEGNO A.1770
disegnato _____ controllato _____
foglio 1 di 1

MATERIALE	GREZZO
TRATTAMENTO	FINITURA LAVORAZ.



PROPRIETA' METIOR srl VIETATA LA RIPRODUZIONE ANCHE PARZIALE SENZA PREVIA AUTORIZZAZIONE

www.metior.it