

cavo m. 7
mod. SLS-0140

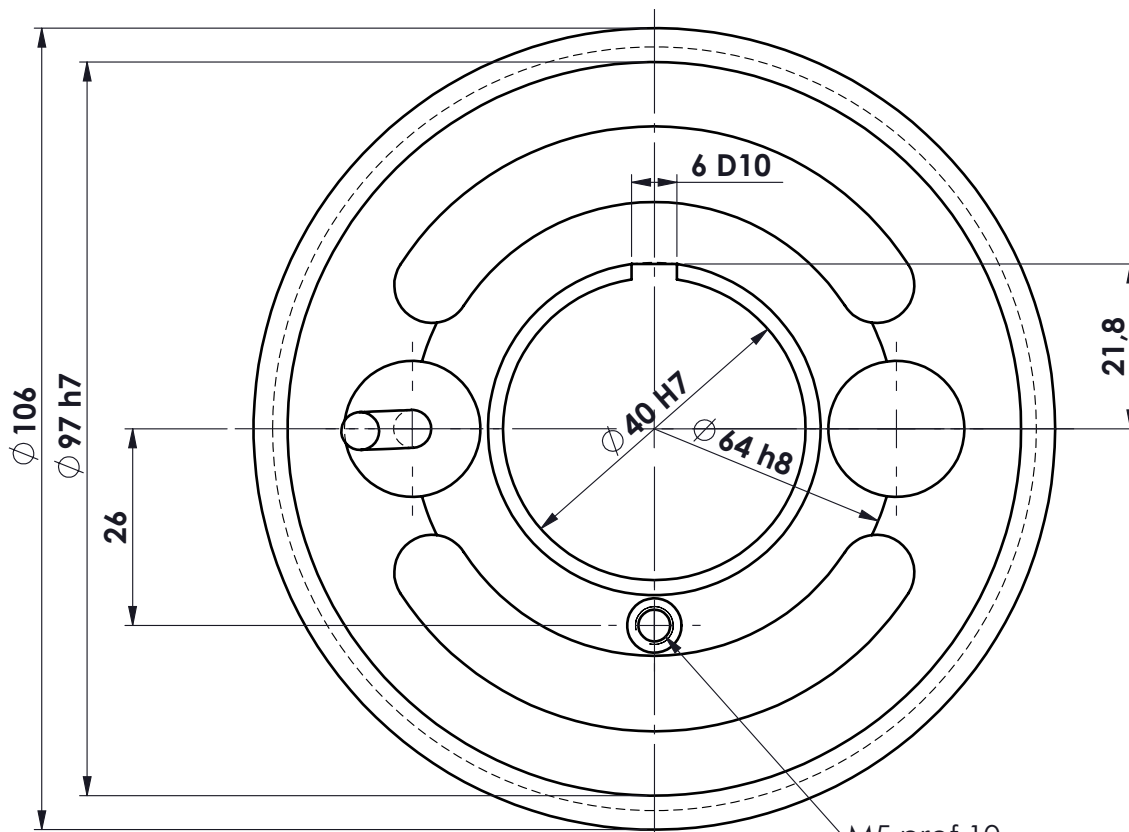

M5 prof.10
n.2 fori opposti

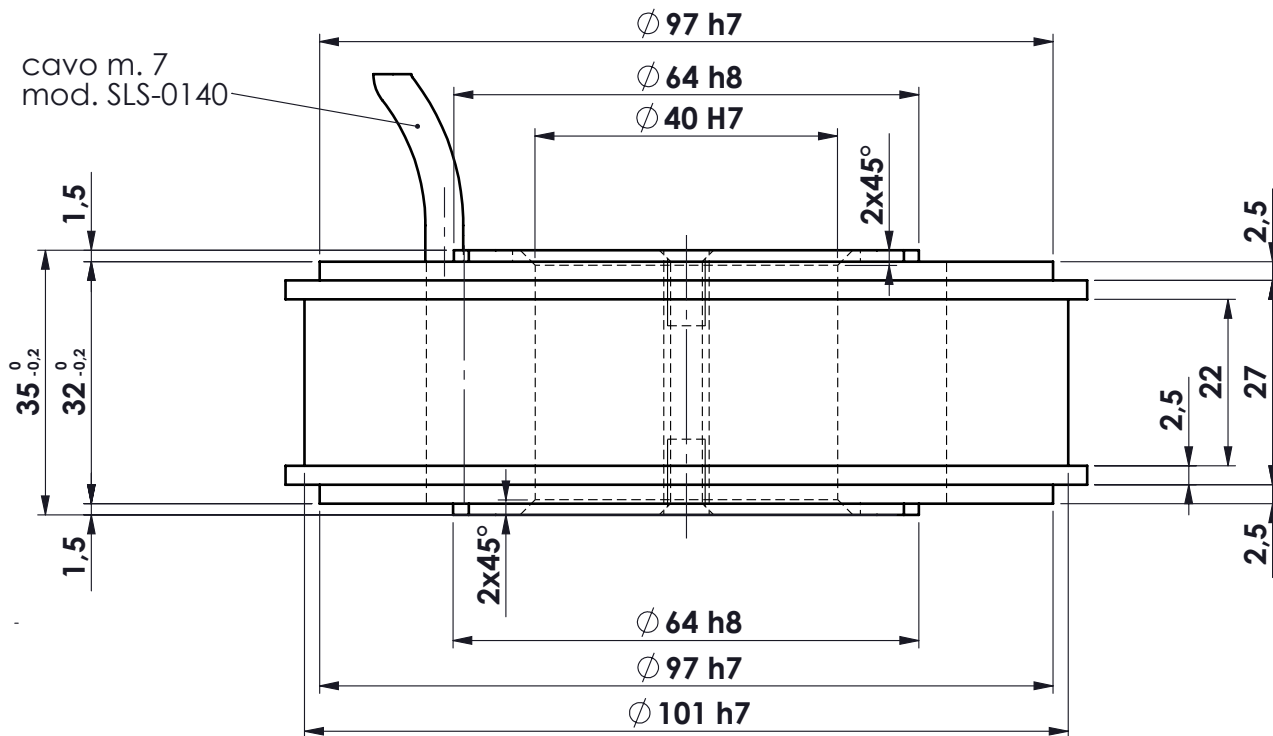
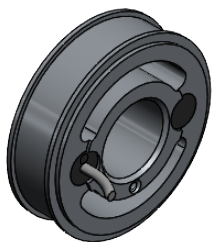

MATERIALE ACCIAIO INOX
PORTATA kg. 3.000-kg.6.000
SENSIBILITA' 1.5 mV/V

toller. gen.	0 ÷ 30	±0.10
	30 ÷ 100	±0.15
	100 ÷ 300	±0.25
	300 ÷ 500	±0.50
	foro/alb	H9 - h9
	sm. e raggi	0.5



peso kg. 1.36
Data 02.09.1993
Scala 1:1

CELLA AL TAGLIO
mod. BLK 3.000-6.000
ASSIEME CELLA

N° DISEGNO A. 192
disegnato FB

foglio 1 di 1
controllato

MATERIALE

GREZZO

TRATTAMENTO

FINITURA LAVORAZ.



METIOR s.r.l.