

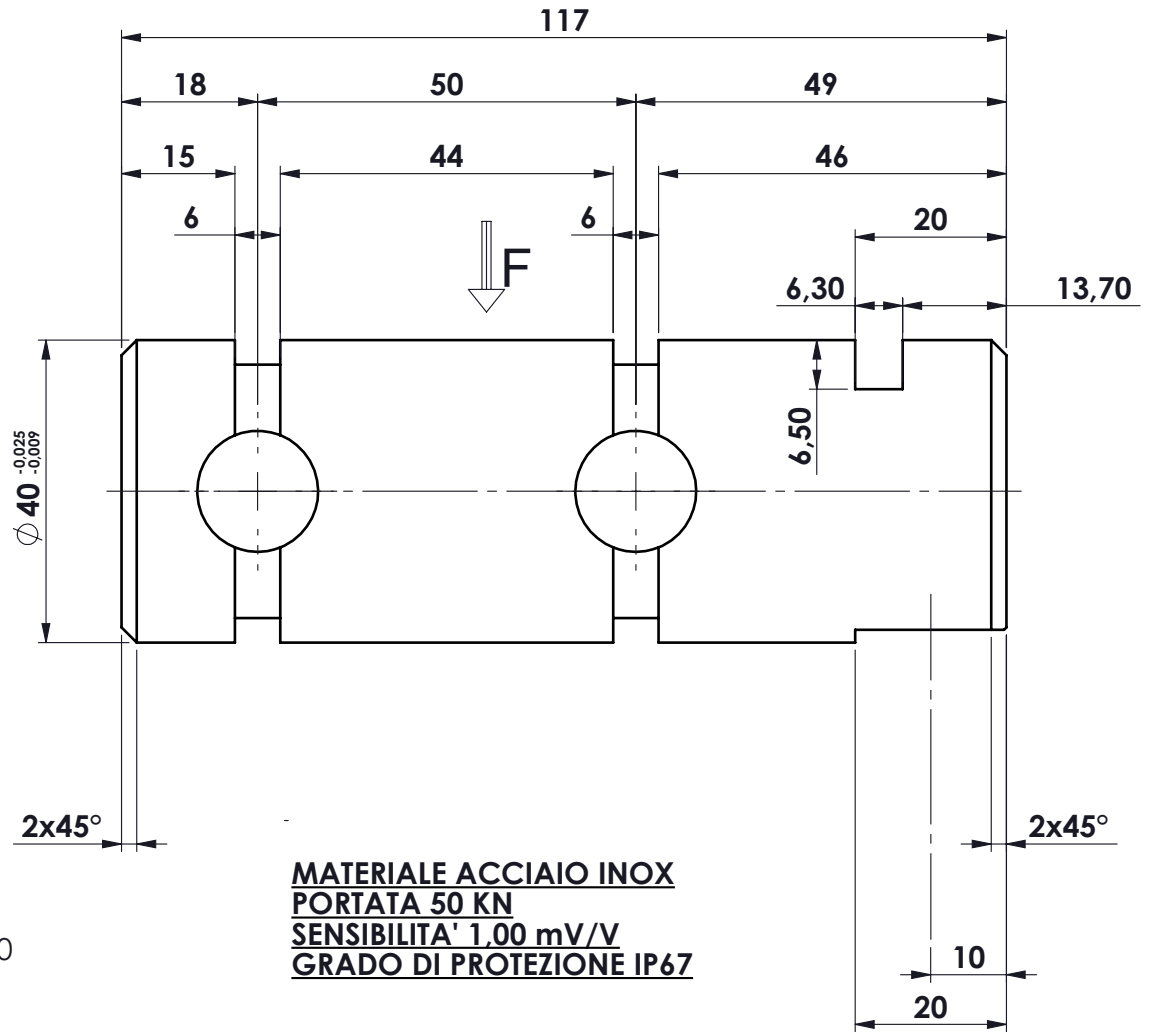

presscavo mod. M8
mt. 10 di cavo mod. SLS-0140

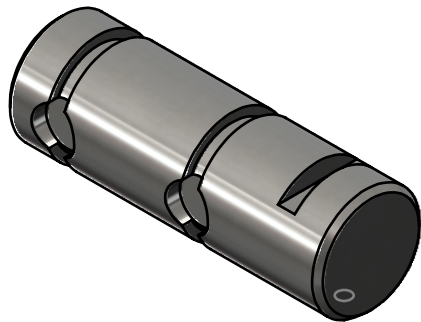

MATERIALE ACCIAIO INOX
PORTATA 50 KN
SENSIBILITA' 1,00 mV/V
GRADO DI PROTEZIONE IP67

						toller. gen.		0 ÷ 30 ±0.10	
								30 ÷ 100 ±0.15	
								100 ÷ 300 ±0.25	
								300 ÷ 500 ±0.50	
								foro/alb H9 - h9	
								sm. e raggi 0.5	
Ap.	Data	Dis.	descrizione modifica		N° DISEGNO		foglio 1		
			peso kg. 1.08	CELLA DI CARICO A PERNO		C.2197		di 1	
			Data 31/01/2022	mod. PRQ 50 KN/12		disegnato		controllato	
			Scala 1:1	ASSIEME		GT			
MATERIALE				GREZZO				 METIOR s.r.l.	
TRATTAMENTO				FINITURA LAVORAZ.					
PROPRIETA' METIOR srl VIETATA LA RIPRODUZIONE ANCHE PARZIALE SENZA PREVA AUTORIZZAZIONE									