

MATERIALE ACCIAIO INOX
PORTATA 50.000 kg
SENSIBILITA' 2,00 mV/V
GRADO DI PROTEZIONE IP65
MARCATURA LPRH 50001

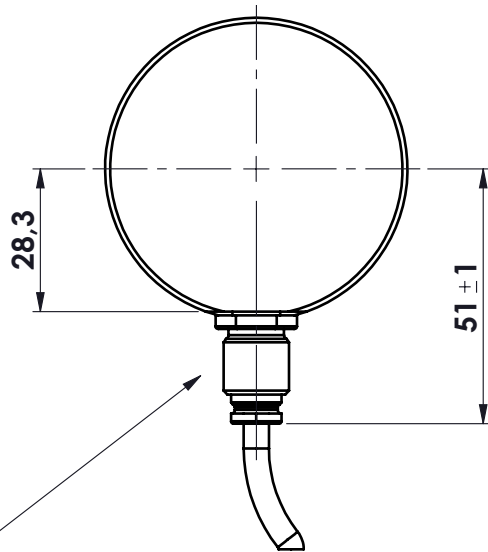

Pressacavo mod. 1/4" GAS
 mt. 5 cavo mod. SLS-0140

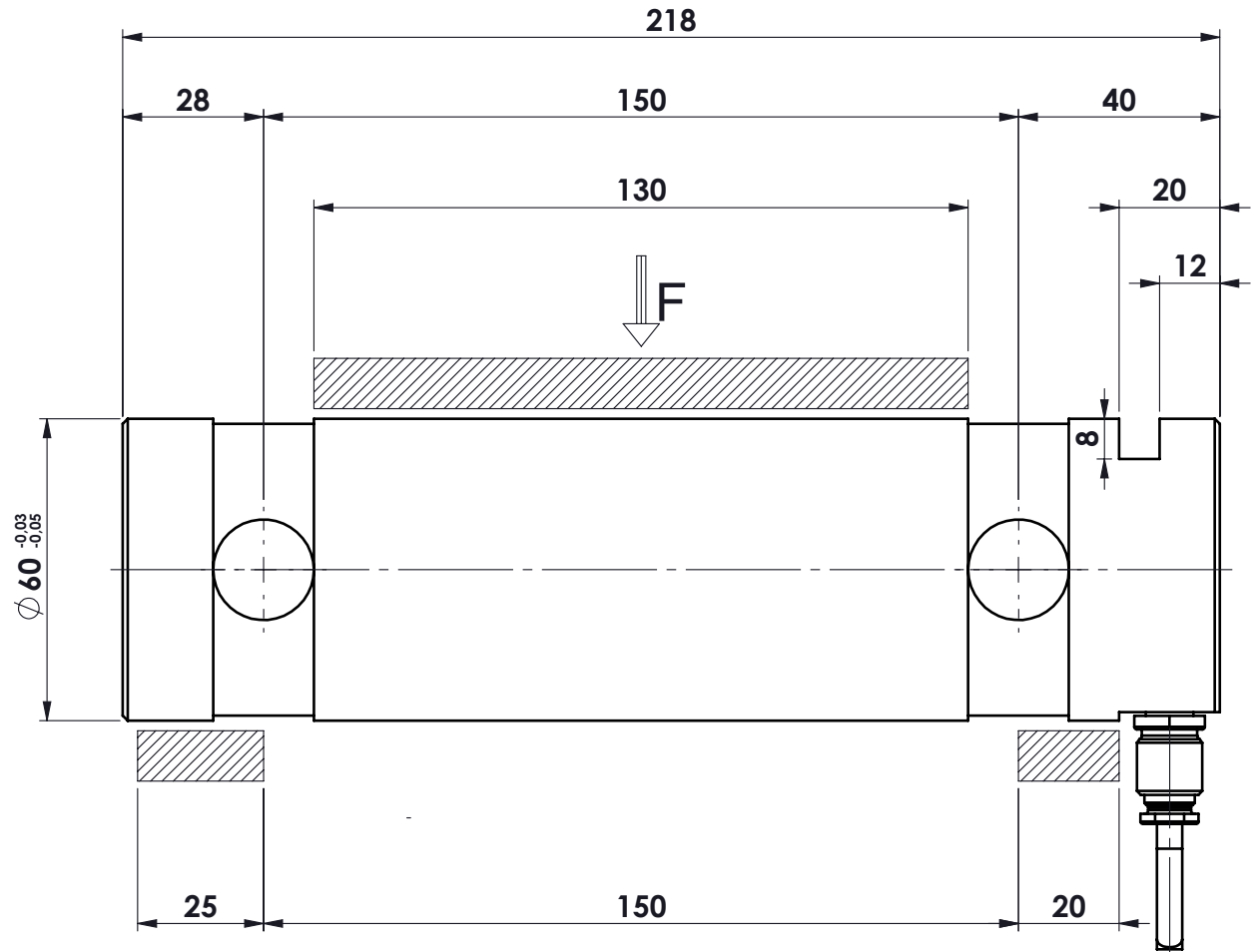
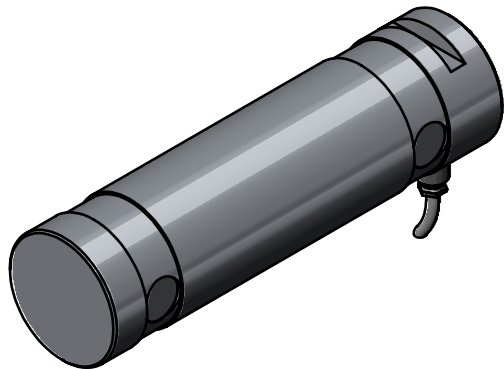

						toller. gen.		0 ÷ 30 ±0.10	
								30 ÷ 100 ±0.15	
								100 ÷ 300 ±0.25	
								300 ÷ 500 ±0.50	
								foro/alb H9 - h9	
								sm. e raggi 0.5	
Ap.	Data	Dis.	descrizione modifica			N° DISEGNO		0 ÷ 30 ±0.10	
			peso kg. 4.86	CELLA DI CARICO A PERNO			C.2222	foglio 1	
			Data 17/05/2022	mod. PRH 50001				di 1	
			Scala 1:1.5	ASSIEME			disegnato GT	controllato	
MATERIALE				GREZZO					
TRATTAMENTO				FINITURA LAVORAZ.					
PROPRIETA' METIOR srl VIETATA LA RIPRODUZIONE ANCHE PARZIALE SENZA PREVIA AUTORIZZAZIONE									

