

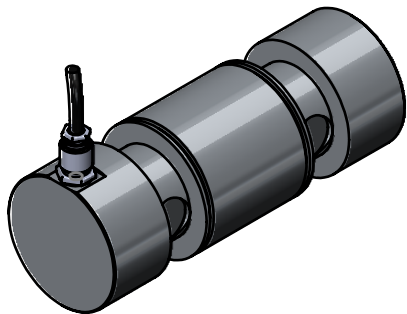

MATERIALE ACCIAIO INOX
PORTATA 10.000 kg
SENSIBILITA' 1,00 mV/V
GRADO DI PROTEZIONE IP65



						toller. gen.		0 ÷ 30 ±0.10	
								30 ÷ 100 ±0.15	
								100 ÷ 300 ±0.25	
								300 ÷ 500 ±0.50	
								foro/alb H9 - h9	
								sm. e raggi 0.5	
Ap.	Data	Dis.	descrizione modifica		N° DISEGNO		C.2247		
		peso kg. 3.15		CELLA DI CARICO A PERNO		disegnato		foglio 1	
		Data 11/10/2022		mod. PRH 10020		GT		di 1	
		Scala 1:1.5		ASSIEME		controllato			
MATERIALE				GREZZO				 METIOR s.r.l.	
TRATTAMENTO				FINITURA LAVORAZ.					
PROPRIETA' METIOR srl VIETATA LA RIPRODUZIONE ANCHE PARZIALE SENZA PREVIA AUTORIZZAZIONE									