

pressacavo PG7  
cavo m.5  
mod. SLS-0224

MATERIALE ACCIAIO INOX  
PORTATA kg.10.000  
SENSIBILITA' 1 mV/V  
protezione IP 68

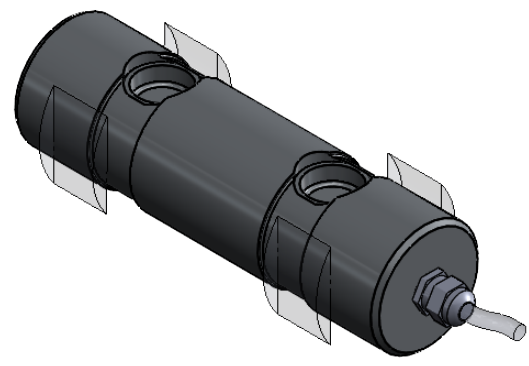

					toller. gen.		0 ÷ 30 ±0.10
							30 ÷ 100 ±0.15
							100 ÷ 300 ±0.25
							300 ÷ 500 ±0.50
							foro/alb H9 - h9
							sm. e raggi 0.5
Ap.	Data	Dis.	descrizione modifica		N° DISEGNO		foglio 1
					C.2027		di 1
			peso kg. 2.58 Data 21.08.2020		CELLA DI CARICO A PERNO mod. PRH 10018 ASSIEME PERNO		disegnato
dimens. in mm.			Scala 1:1		GT		controllato
MATERIALE				GREZZO			
TRATTAMENTO				FINITURA LAVORAZ.			
PROPRIETA' METIOR srl VIETATA LA RIPRODUZIONE ANCHE PARZIALE SENZA PREVIA AUTORIZZAZIONE							

