

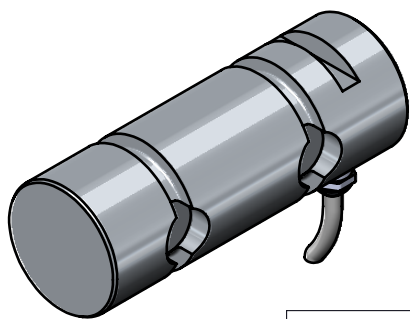

pressacavo M8
cavo m.5
mod. SLS-0400 HT

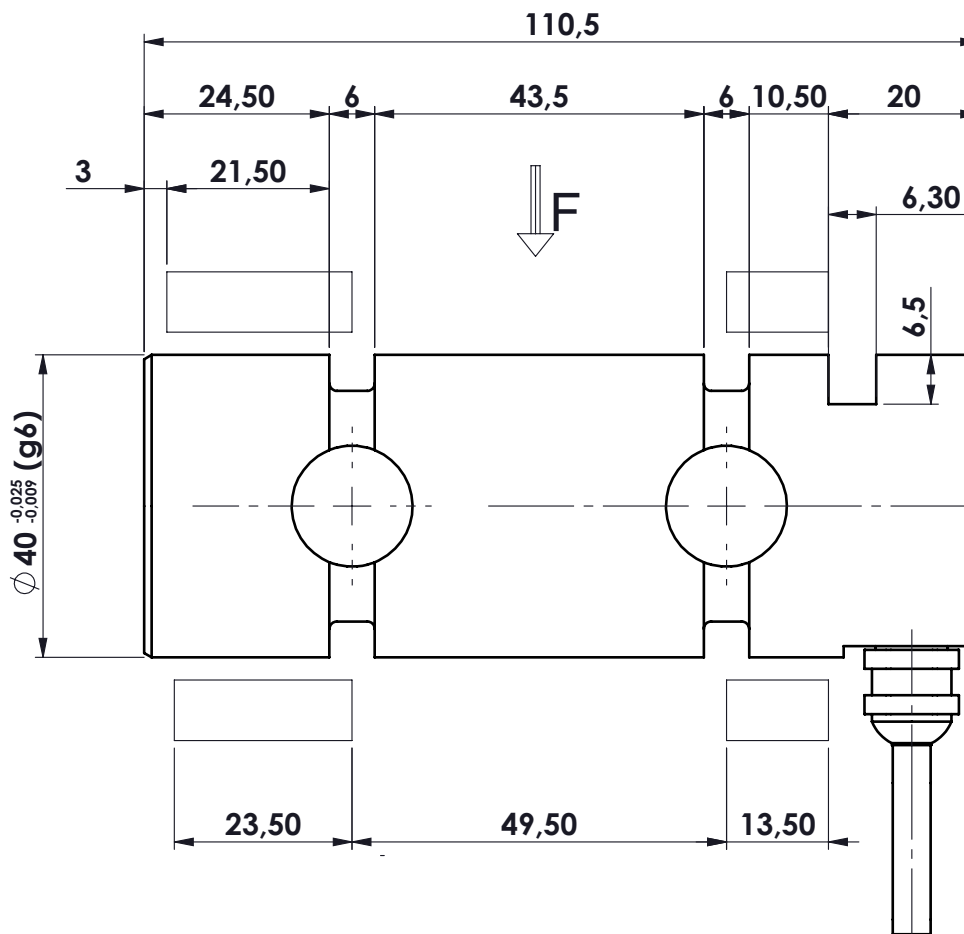

dove non specificato
tolleranza ± 0.3 mm.



MATERIALE ACCIAIO INOX 17-4-PH
PORTATA: 30 kN
SENSIBILITA' 1 mV/V
protezione IP65

						toller. gen.		0 ÷ 30 ±0.10	
								30 ÷ 100 ±0.15	
								100 ÷ 300 ±0.25	
								300 ÷ 500 ±0.50	
								foro/alb H9 - h9	
								sm. e raggi 0.5	
Ap.	Data	Dis.	descrizione modifica		N° DISEGNO		foglio 1		
			peso kg. 1.02	CELLA DI CARICO A PERNO		C.2100		di 1	
			Data 26.01.2021	PRQ 30 KN/4		disegnato		controllato	
			Scala 1:1	ASSIEME		GT			
MATERIALE				GREZZO				 METIOR s.r.l.	
TRATTAMENTO				FINITURA LAVORAZ.					
PROPRIETA' METIOR srl VIETATA LA RIPRODUZIONE ANCHE PARZIALE SENZA PREVA AUTORIZZAZIONE									