

ZONA ATEX:
 II 2G Ex ib IIC T6/T5/T4 Gb
 II 2D Ex ib IIIC T85/100/135°C Db
 PR 17/04IS02025

pressacavo mod. PG7
 mt. 20 cavo mod. SLS-0224

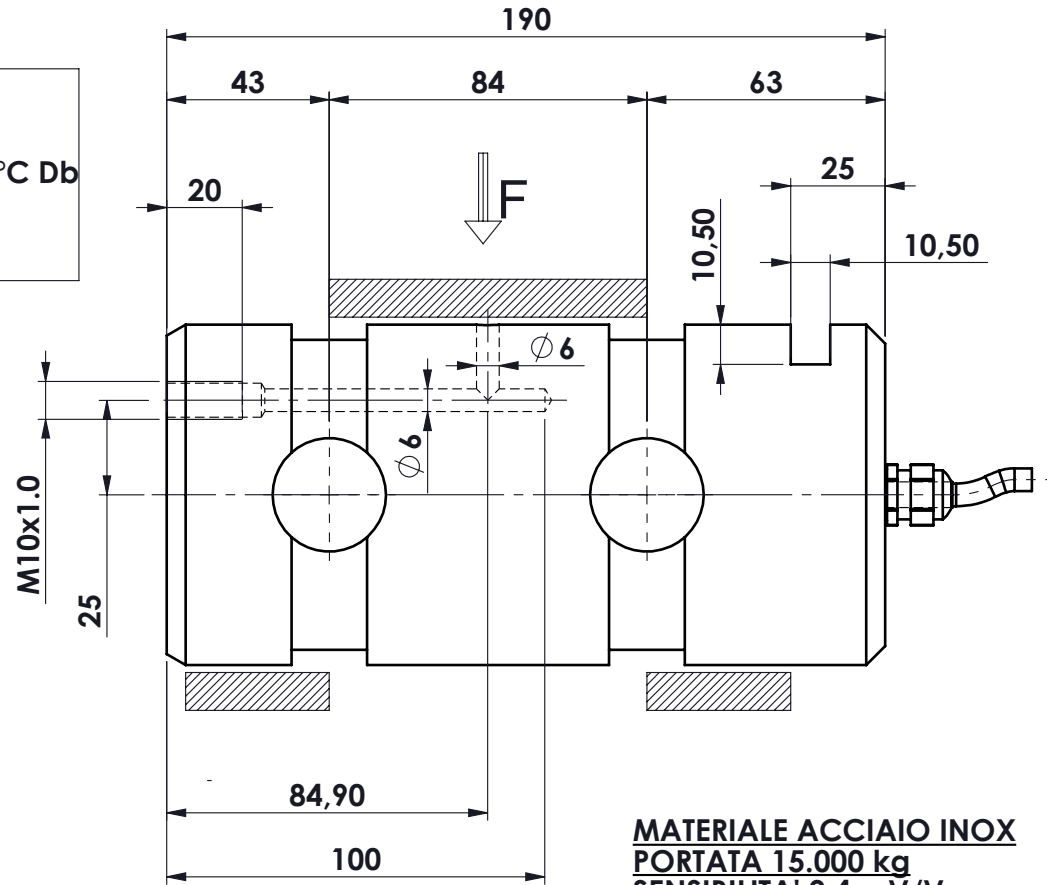

MATERIALE ACCIAIO INOX
PORTATA 15.000 kg
SENSIBILITA' 0,4 mV/V
GRADO DI PROTEZIONE IP67

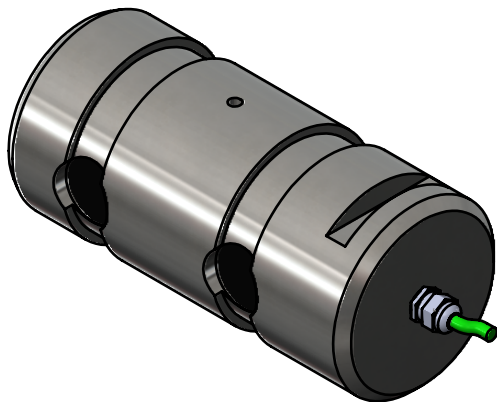

						toller. gen.		0 ÷ 30 ±0.10	
								30 ÷ 100 ±0.15	
								100 ÷ 300 ±0.25	
								300 ÷ 500 ±0.50	
								foro/alb H9 - h9	
								sm. e raggi 0.5	
Ap.	Data	Dis.	descrizione modifica		N° DISEGNO		C.2123.EX		
		peso kg. 8.92		CELLA DI CARICO A PERNO		disegnato		foglio 1	
		Data 24/05/2021		mod. PRT 15001		GT		di 1	
		Scala 1:2		CELLA IN COMPRESSIONE		controllato			
MATERIALE				GREZZO				 METIOR s.r.l.	
TRATTAMENTO				FINITURA LAVORAZ.					
PROPRIETA' METIOR srl VIETATA LA RIPRODUZIONE ANCHE PARZIALE SENZA PREVIA AUTORIZZAZIONE									