

pressacavo mod. PG7
m. 5 di cavo
mod. SLS-0224

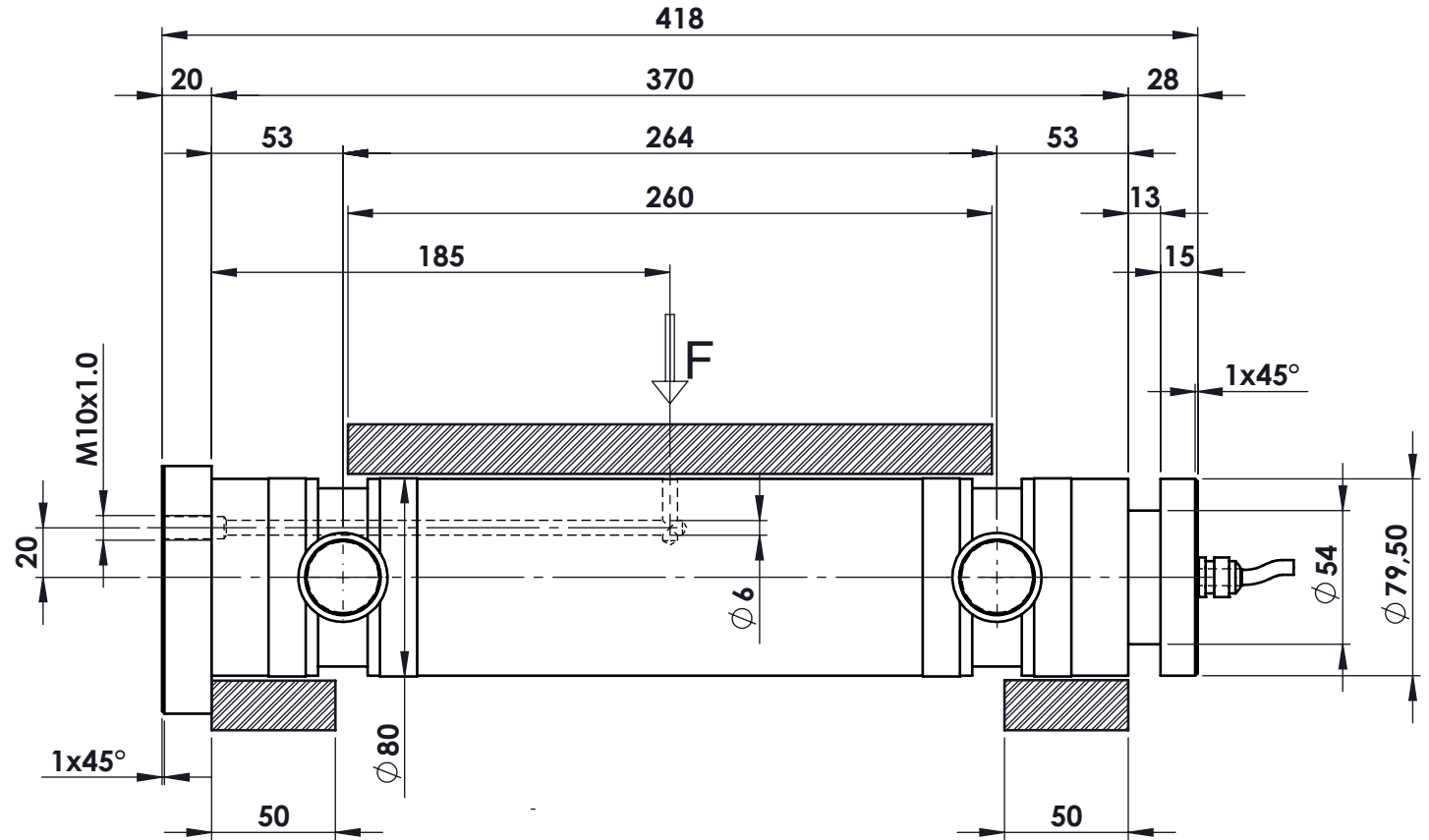

MATERIALE ACCIAIO INOX
PORTATA 50.000 kg
SENSIBILITA' 1,5 mV/V
GRADO DI PROTEZIONE IP68

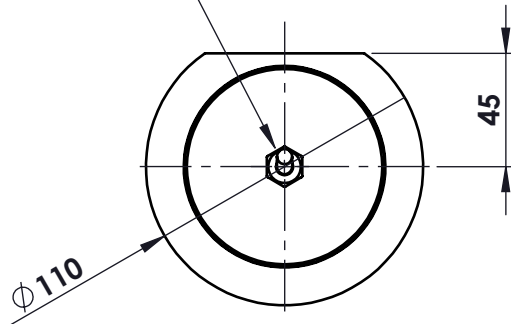
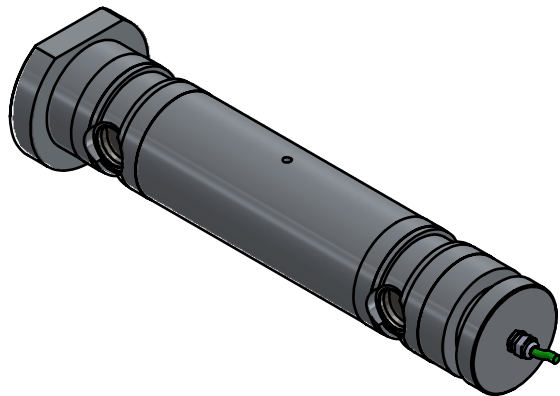

toller. gen.	0 ÷ 30	±0.10
	30 ÷ 100	±0.15
	100 ÷ 300	±0.25
	300 ÷ 500	±0.50
	foro/alb H9 - h9	sm. e raggi 0.5

	peso kg. 16.11	CELLA DI CARICO A PERNO mod. PRT 50.000/6 ASSIEME	N° DISEGNO	C.1928	foglio 1 di 1
	dimens. in mm.		Data 04/07/2019	disegnato	GT
MATERIALE	GREZZO				
TRATTAMENTO	FINITURA LAVORAZ.				
PROPRIETA' METIOR srl VIETATA LA RIPRODUZIONE ANCHE PARZIALE SENZA PREVA AUTORIZZAZIONE					

 **METIOR** s.r.l.