

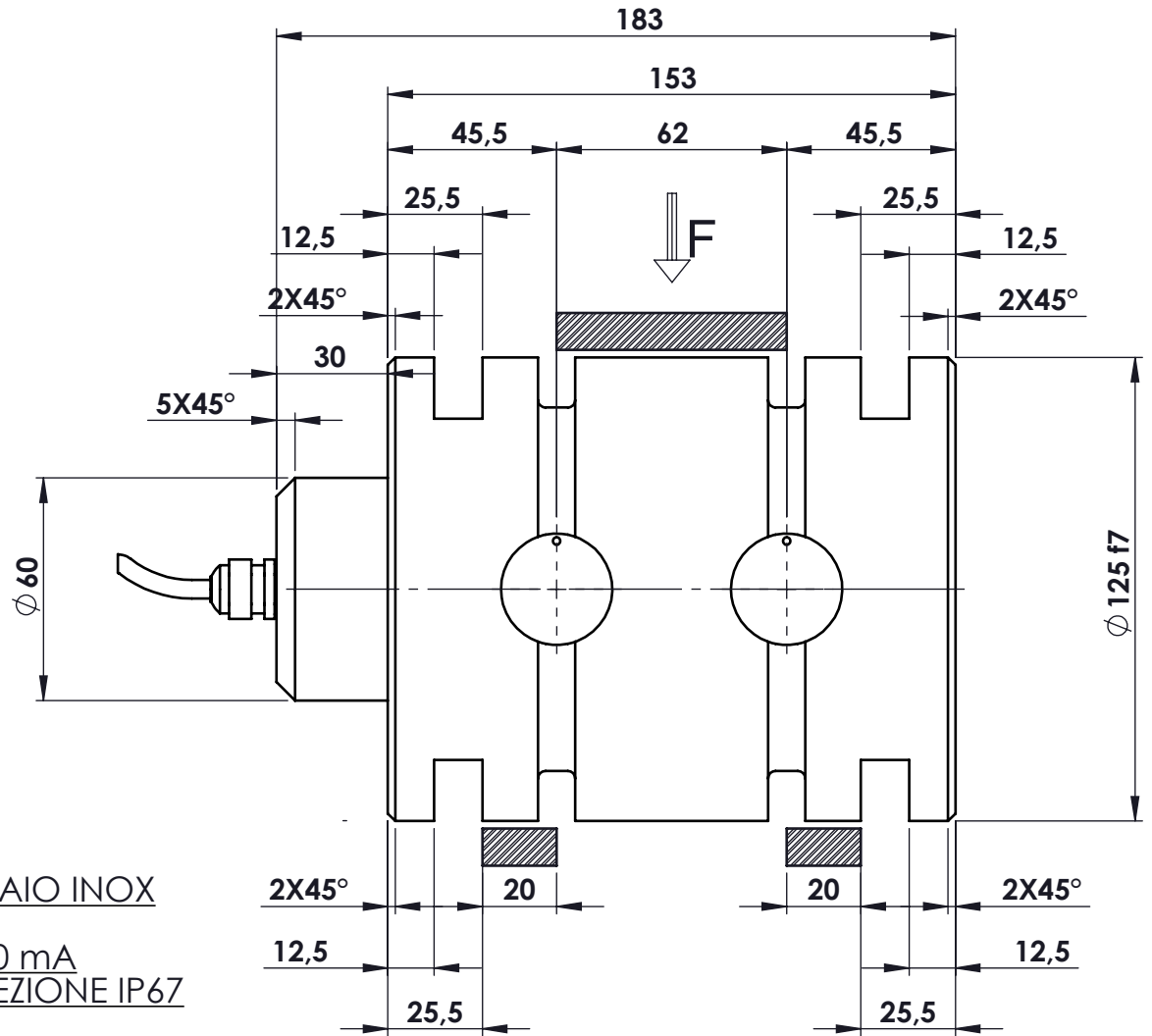

pressacavo mod. PG7
mt.5 di cavo mod. SLS-0140

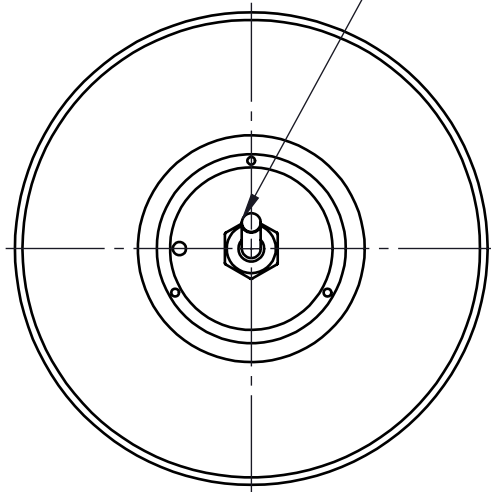

MATERIALE ACCIAIO INOX
PORTATA 850 KN
SENSIBILITA' 4 ÷ 20 mA
GRADO DI PROTEZIONE IP67

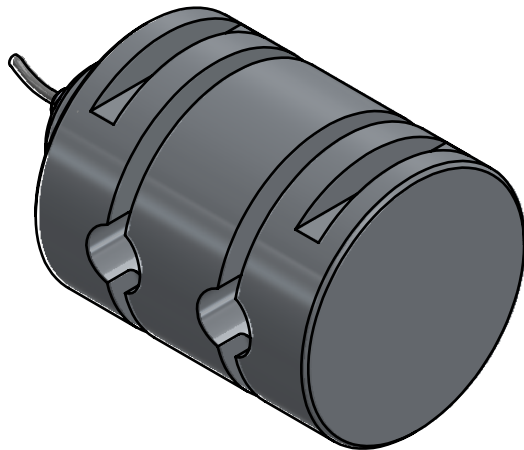
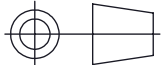

						toller. gen.		0 ÷ 30 ±0.10	
								30 ÷ 100 ±0.15	
								100 ÷ 300 ±0.25	
								300 ÷ 500 ±0.50	
								foro/alb H9 - h9	
								sm. e raggi 0.5	
Ap.	Data	Dis.	descrizione modifica		N° DISEGNO		C.1922		
 dimens. in mm. Scala 1:2		peso kg. 14.20	CELLA DI CARICO A PERNO		disegnato		foglio 1		
		Data 21/06/2019	mod. PRZ 850 KN		GT		di 1		
			ASSIEME		controllato				
MATERIALE				GREZZO				 METIOR s.r.l.	
TRATTAMENTO				FINITURA LAVORAZ.					
PROPRIETA' METIOR srl VIETATA LA RIPRODUZIONE ANCHE PARZIALE SENZA PREVIA AUTORIZZAZIONE									