

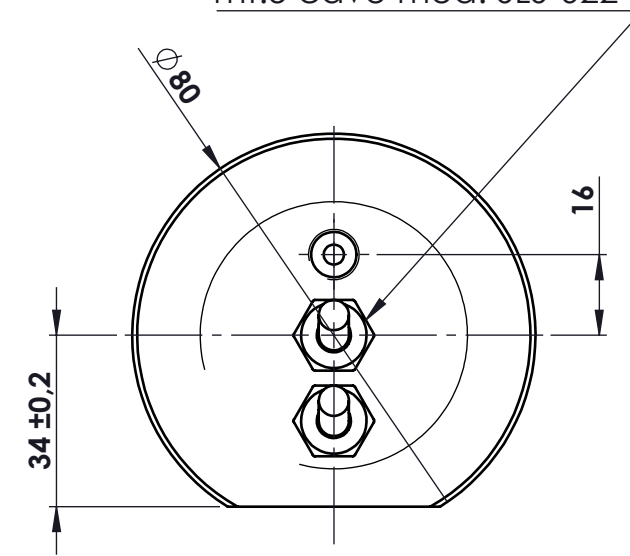

N. 2
Pressacavo mod. PG7
mt.5 cavo mod. SLS-0224

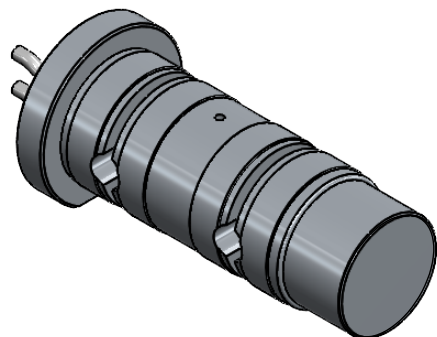

MATERIALE ACCIAIO INOX
PORTATA 100 KN
SENSIBILITA' 1 mV/V
GRADO DI PROTEZIONE IP67
DOPPIO PONTE ESTENSIMETRICO



						toller. gen.		0 ÷ 30 ±0.10	
								30 ÷ 100 ±0.15	
								100 ÷ 300 ±0.25	
								300 ÷ 500 ±0.50	
								foro/alb H9 - h9	
								sm. e raggi 0.5	
Ap.	Data	Dis.	descrizione modifica		N° DISEGNO		C.1923		
 dimens. in mm.		 Scala 1:1.5		peso kg. 3.70 Data 24/06/2019		CELLE DI CARICO A PERNO mod. PRH 100 KN/9 DOP ASSIEME		foglio 1 di 1	
MATERIALE				GREZZO				disegnato GT	
TRATTAMENTO				FINITURA LAVORAZ.				controllato	
PROPRIETA' METIOR srl VIETATA LA RIPRODUZIONE ANCHE PARZIALE SENZA PREVA AUTORIZZAZIONE									

 **METIOR** s.r.l.