

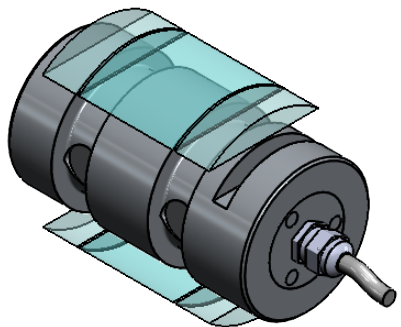

pressacavo PG7
cavo m.5
mod. SLS-0224

MATERIALE ACCIAIO INOX
PORTATA 125 kN
SENSIBILITA' 1 mV/V
protezione IP65



			toller. gen.		0 ÷ 30 ±0.10
					30 ÷ 100 ±0.15
					100 ÷ 300 ±0.25
					300 ÷ 500 ±0.50
					foro/alb H9 - h9
					sm. e raggi 0.5
Ap.	Data	Dis.	descrizione modifica		
			peso kg. 2.20	CELLA DI CARICO A PERNO	
			Data 14.01.2016	mod. PRH 125 kN	
			dimens. in mm.	ASSIEME CELLA	
			Scala 1:1		
MATERIALE			GREZZO		
TRATTAMENTO			FINITURA LAVORAZ.		
PROPRIETA' METIOR srl VIETATA LA RIPRODUZIONE ANCHE PARZIALE SENZA PREVIA AUTORIZZAZIONE					
			N° DISEGNO C.1606		foglio 1 di 1
			disegnato FB		controllato
			 METIOR s.r.l.		