

MATERIALE ACCIAIO INOX
 PORTATA 2.000 kg.
 SENSIBILITA' 1 mV/V

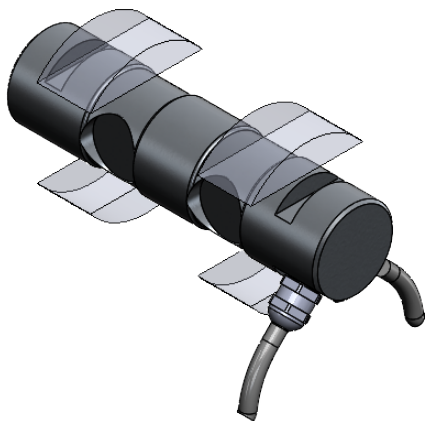

					toller. gen.		0 ÷ 30 ±0.10
							30 ÷ 100 ±0.15
							100 ÷ 300 ±0.25
							300 ÷ 500 ±0.50
							foro/alb H9 - h9
							sm. e raggi 0.5
Ap.	Data	Dis.	descrizione modifica		N° DISEGNO		0 ÷ 30 ±0.10
					C.1696		foglio 1
					disegnato		di 1
					MR		controllato
MATERIALE			GREZZO				
TRATTAMENTO			FINITURA LAVORAZ.				
PROPRIETA' METIOR srl VIETATA LA RIPRODUZIONE ANCHE PARZIALE SENZA PREVA AUTORIZZAZIONE							

 **METIOR** s.r.l.