

pressacavo M8
cavo m.5
mod. SLS-0091 (nero)

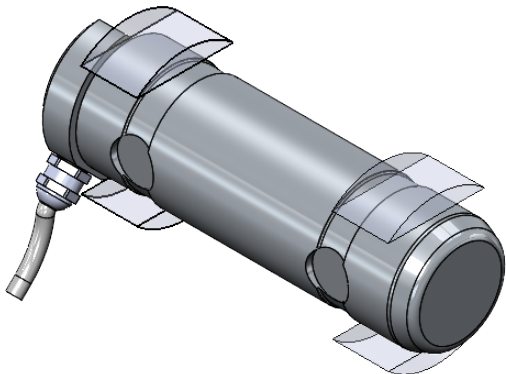
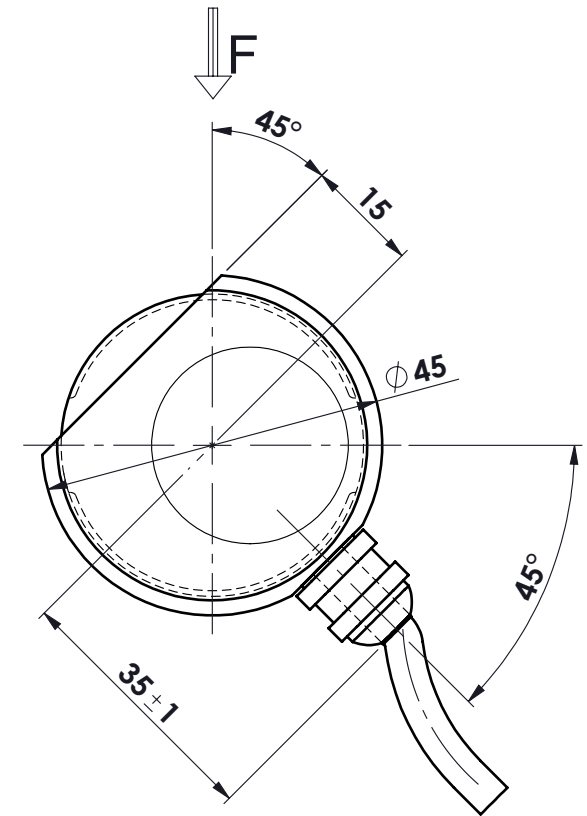

MATERIALE ACCIAIO INOX
PORTATA 12.000 kg.
SENSIBILITA' 1 mV/V
protezione IP65

toller. gen.	0 ÷ 30	±0.10
	30 ÷ 100	±0.15
	100 ÷ 300	±0.25
	300 ÷ 500	±0.50
	foro/alb H9 - h9	sm. e raggi 0.5

	peso kg. 1.36	CELLA DI CARICO A PERNO mod. PRQ 12.000 ASSIEME CELLA	N° DISEGNO C.1587	foglio 1
	Data 29.10.2015		di 1	
dimens. in mm.	Scala 1:1		disegnato FB	controllato
MATERIALE		GREZZO		
TRATTAMENTO		FINITURA LAVORAZ.		
PROPRIETA' METIOR srl VIETATA LA RIPRODUZIONE ANCHE PARZIALE SENZA PREVIA AUTORIZZAZIONE				

