

MATERIALE ACCIAIO INOX  
 PORTATA 20.000 kg.  
 SENSIBILITA' 2 mV/V  
 protezione IP65  
 marchiatura: **SPR20000DG**

toller. gen.	0 ÷ 30	±0.10
	30 ÷ 100	±0.15
	100 ÷ 300	±0.25
	300 ÷ 500	±0.50
	foro/alb H9 - h9	
	sm. e raggi	0.5

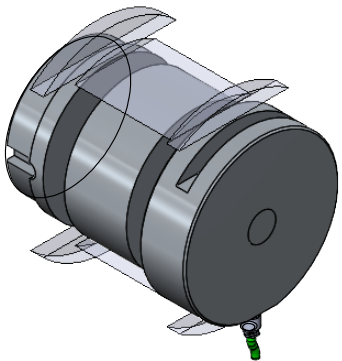

	peso kg. 15.78	CELLA DI CARICO A PERNO mod. PRZ 20.003 ASSIEME CELLA
	Data 01.12.2015	
dimens. in mm. Scala 1:2		
MATERIALE	GREZZO	
TRATTAMENTO	FINITURA LAVORAZ.	
PROPRIETA' METIOR srl VIETATA LA RIPRODUZIONE ANCHE PARZIALE SENZA PREVIA AUTORIZZAZIONE		

N° DISEGNO	C.1594	foglio 1 di 1
disegnato	FB	controllato

