

Pressacavo 1/2 GAS
Cavo m. 5
mod. SLS-0224

SEZIONE A-A

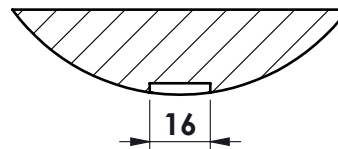

MATERIALE ACCIAIO INOX
PORTATA 260 kN
SENSIBILITA' 1 mV/V
Protezione IP 68

toller. gen.	0 ÷ 30	±0.10
	30 ÷ 100	±0.15
	100 ÷ 300	±0.25
	300 ÷ 500	±0.50
	foro/alb H9 - h9	sm. e raggi 0.5

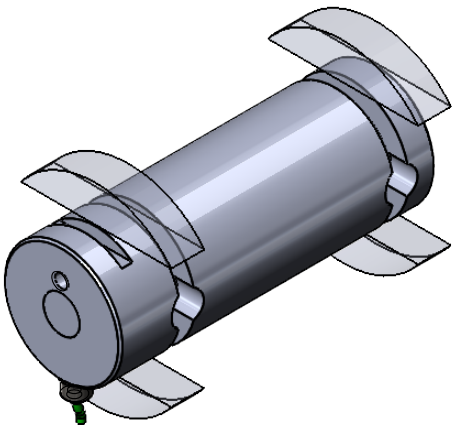

 dimens. in mm.	peso kg. 3.04 Data 18.05.2015	CELLA A PERNO mod. PRZ 260 kN INGOMBRO
	Scala 1:2	
MATERIALE	GREZZO	N° DISEGNO C.1550 foglio 1 di 1 disegnato MR controllato
TRATTAMENTO	FINITURA LAVORAZ.	
PROPRIETA' METIOR srl VIETATA LA RIPRODUZIONE ANCHE PARZIALE SENZA PREVIA AUTORIZZAZIONE		

