

ZONA ATEX:

II 2G, Ex ib IIC T6/T5/T4 Gb

II 2D, Ex ib IIIC T85/T100/T135°C Db

STRINGA Ex:

PR 17/04IS00510

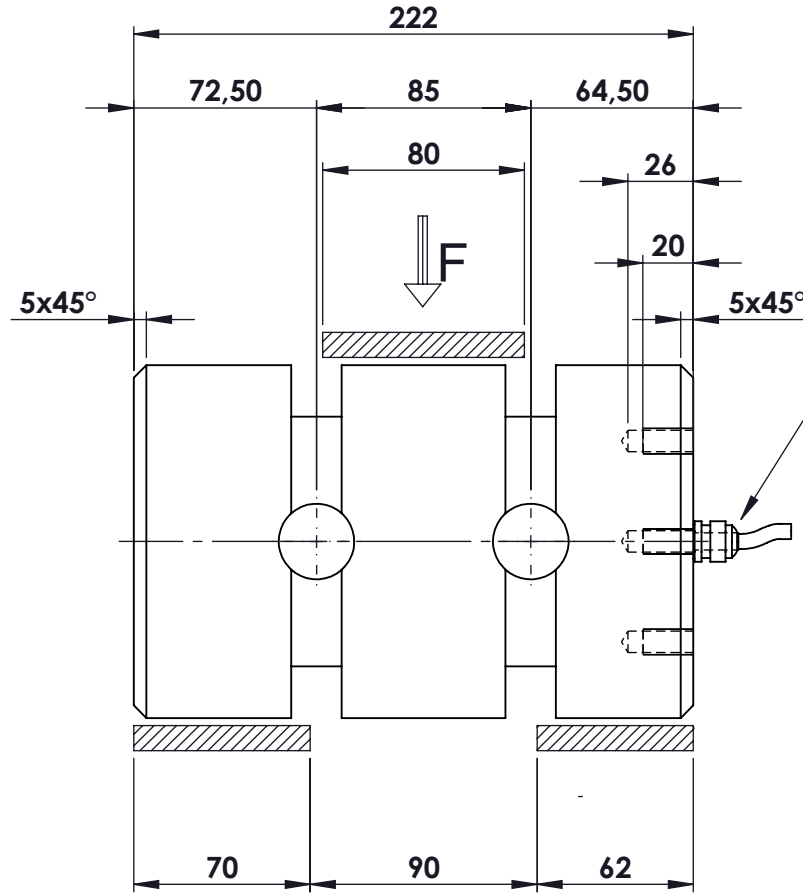
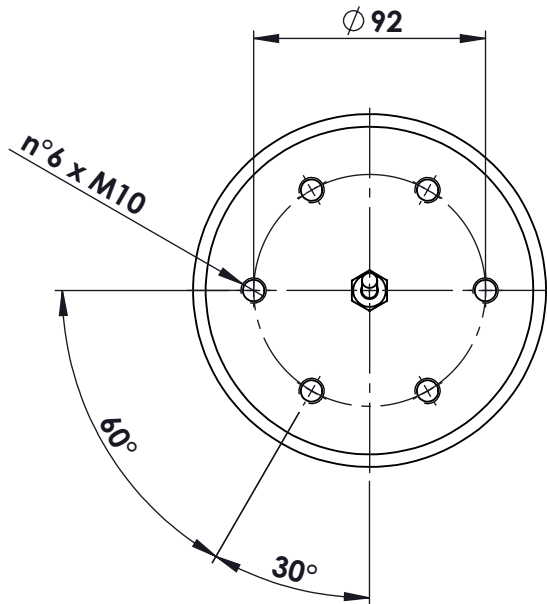

Pressacavo mod. PG7
mt. 5 di cavo mod. SLS-0240

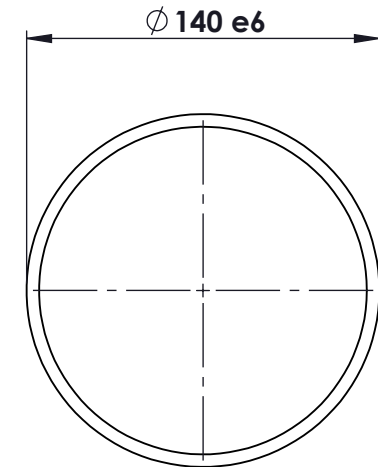

MATERIALE ACCIAIO INOX
PORTATE 150 kN ÷ 950 kN
SENSIBILITA' 1,00 mV/V
GRADO DI PROTEZIONE IP67

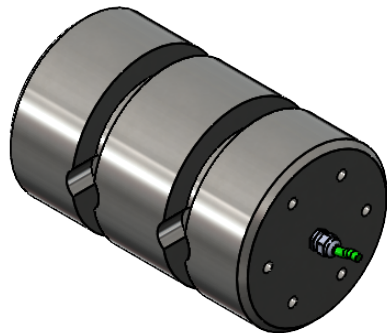

						toller. gen.		0 ÷ 30 ±0.10	
								30 ÷ 100 ±0.15	
								100 ÷ 300 ±0.25	
								300 ÷ 500 ±0.50	
								foro/alb H9 - h9	
								sm. e raggi 0.5	
Ap.	Data	Dis.	descrizione modifica						
		peso kg. 23.96		CELLA DI CARICO A PERNO		N° DISEGNO C.2061.EX		foglio 1	
		Data 30/11/2020		mod. PRZ 150 kN/1 - 950 kN				di 1	
		Scala 1:3		ASSIEME		disegnato GT		controllato	
MATERIALE				GREZZO					
TRATTAMENTO				FINITURA LAVORAZ.					
PROPRIETA' METIOR srl VIETATA LA RIPRODUZIONE ANCHE PARZIALE SENZA PREVA AUTORIZZAZIONE									

