

pressacavo PG7
cavo m.5
mod. SLS-0224

18 ± 1

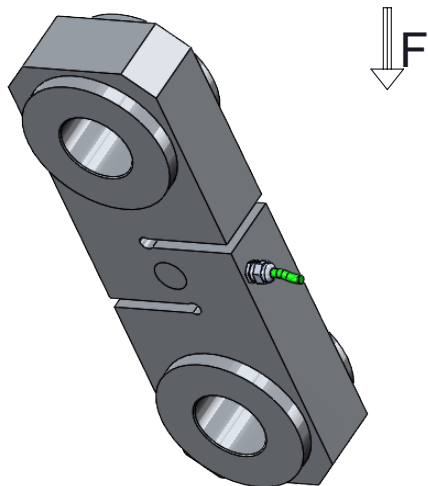

MATERIALE ACCIAIO INOX
PORTATA 20.000 kg.
SENSIBILITA' 2 mV/V
protezione IP65

toler. gen.	0 ÷ 30	±0.10
	30 ÷ 100	±0.15
	100 ÷ 300	±0.25
	300 ÷ 500	±0.50
	foro/alb	H9 - h9
	sm. e raggi	0.5



peso kg. 17.78
Data 14.01.1993
Scala 1:2.5

DINAMOMETRO
mod. TRK 20.000
ASSIEME CELLA

N° DISEGNO B.168

foglio 1
di 1

disegnato FB

controllato

MATERIALE

GREZZO

TRATTAMENTO

FINITURA LAVORAZ.



METIOR s.r.l.