

Pressacavo mod. PG7  
mt.7 cavo mod. SLS-0224

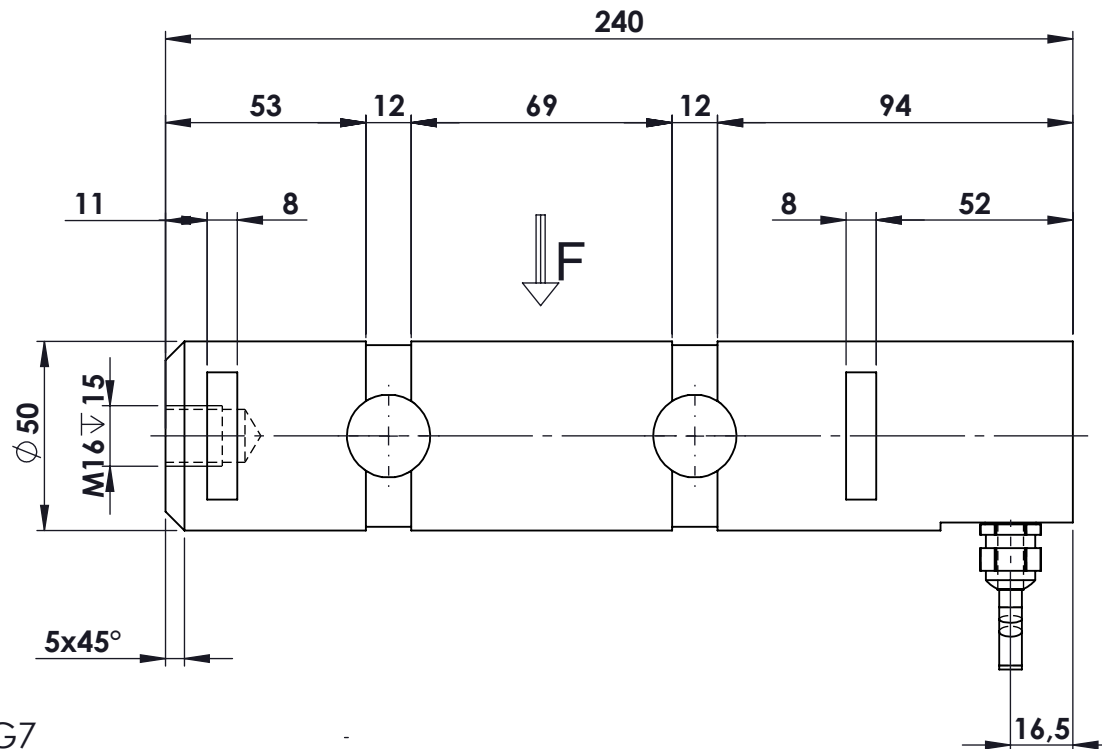

**MATERIALE ACCIAIO INOX**  
**PORTATA 100 kN**  
**SENSIBILITAT 1,00 mV/V**  
**GRADO DI PROTEZIONE IP67**  
**MARCATURA LPRH 100kN**

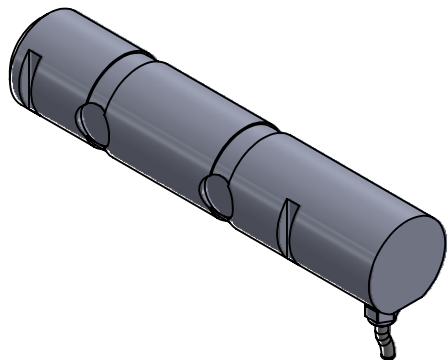

					toller. gen.		0 ÷ 30 ±0.10
							30 ÷ 100 ±0.15
							100 ÷ 300 ±0.25
							300 ÷ 500 ±0.50
							foro/alb H9 - h9
							sm. e raggi 0.5
Ap.	Data	Dis.	descrizione modifica		N° DISEGNO		foglio 1
			peso kg. 3,00		C.2406		di 1
			Data 07.05.2024		disegnato		controllato
			dimens. in mm. Scala 1:2		GT		
MATERIALE					GREZZO		
TRATTAMENTO					FINITURA LAVORAZ.		
PROPRIETA' METIOR srl VIETATA LA RIPRODUZIONE ANCHE PARZIALE SENZA PREVA AUTORIZZAZIONE							

 **METIOR** s.r.l.