

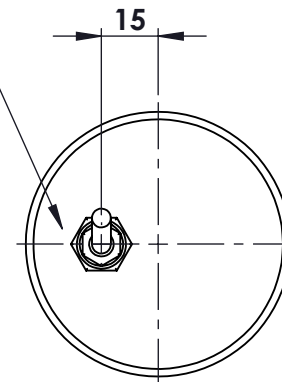

Pressacavo mod. 1/4"GAS
mt. 5 cavo mod. SLS-0140

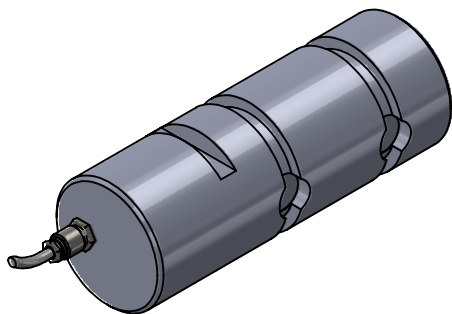

MATERIALE ACCIAIO INOX
PORTATA 15000 kg
SENSIBILITA' 1,00 mV/V
GRADO DI PROTEZIONE IP67
MARCATURA SLC-E15-MVM



			toller. gen.		0 ÷ 30 ±0.10
					30 ÷ 100 ±0.15
					100 ÷ 300 ±0.25
					300 ÷ 500 ±0.50
					foro/alb H9 - h9
					sm. e raggi 0.5
Ap.	Data	Dis.	descrizione modifica		
			peso kg. 4,00	CELLA DI CARICO A PERNO	
			Data 01.07.2024	mod. PRH 15013	
			dimens. in mm.	Scala 1:2	ASSIEME
MATERIALE			GREZZO		
TRATTAMENTO			FINITURA LAVORAZ.		
PROPRIETA' METIOR srl VIETATA LA RIPRODUZIONE ANCHE PARZIALE SENZA PREVIA AUTORIZZAZIONE					
			N° DISEGNO C.2420		foglio 1 di 1
			disegnato GT		controllato
			 METIOR s.r.l.		