

MATERIALE ACCIAIO INOX
 PORTATA 50 kN
 SENSIBILITA' 1 mV/V
 protezione IP 68

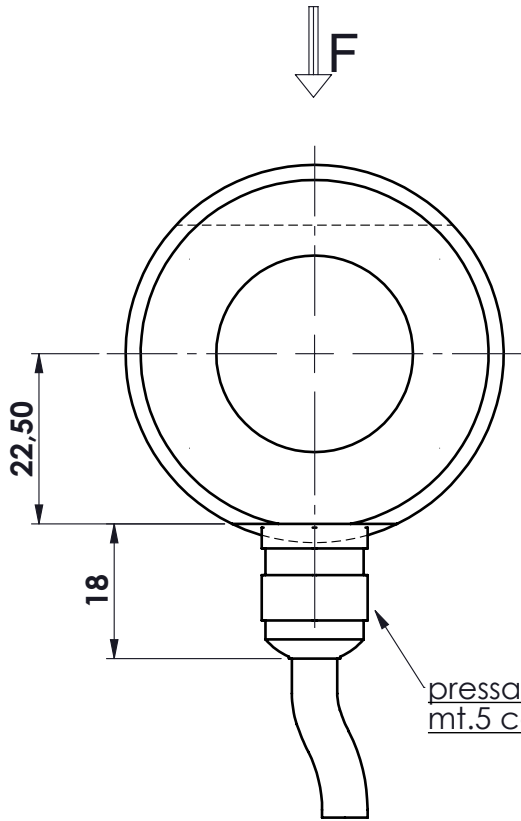

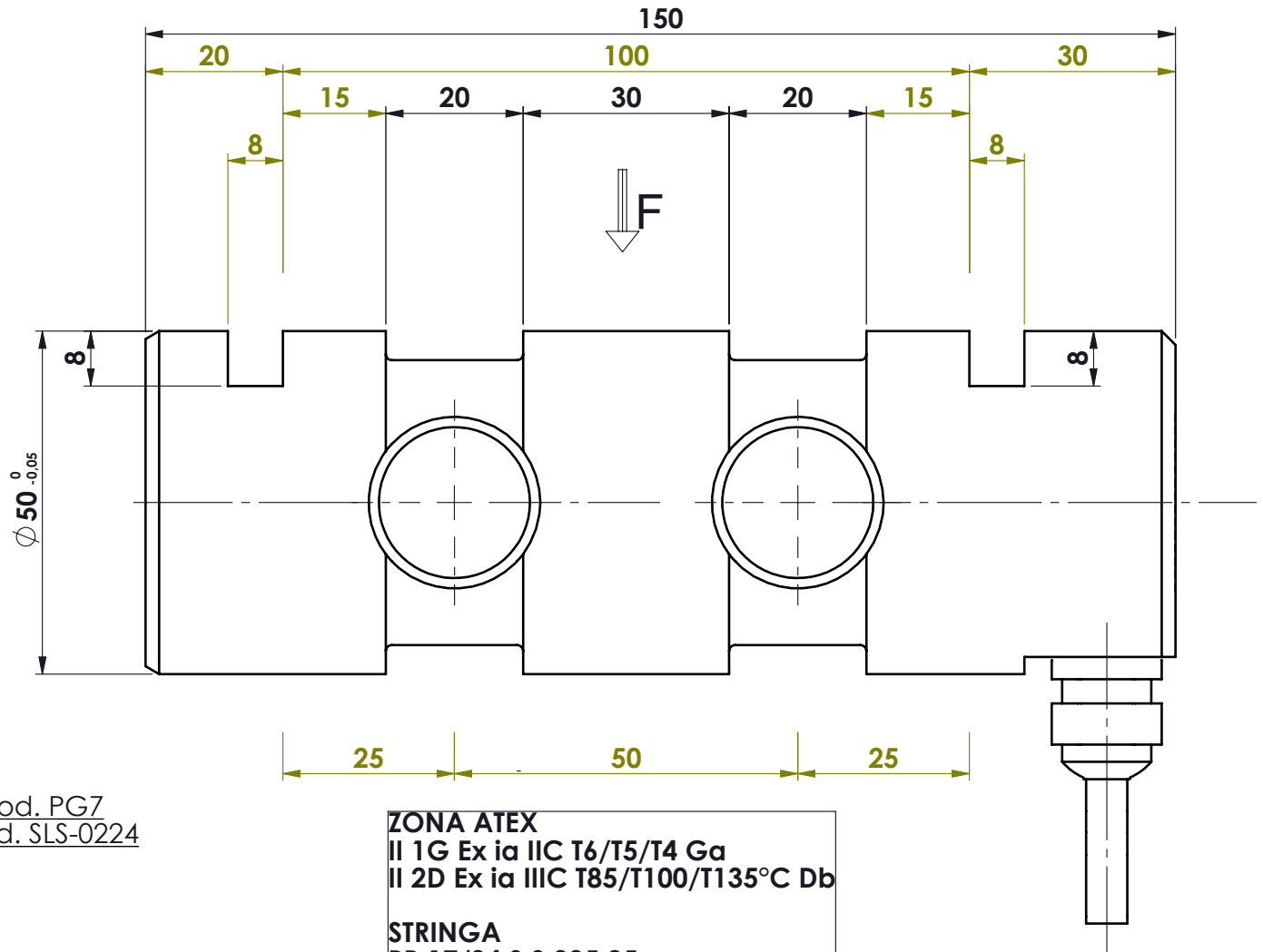

pressacavo mod. PG7
 mt.5 cavo mod. SLS-0224

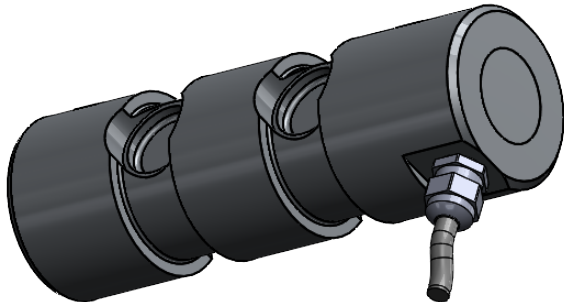

ZONA ATEX
 II 1G Ex ia IIC T6/T5/T4 Ga
 II 2D Ex ia IIIC T85/T100/T135°C Db

STRINGA
 PR 17/04 S S 005 25



					toller. gen.		0 ÷ 30 ±0.10
							30 ÷ 100 ±0.15
							100 ÷ 300 ±0.25
							300 ÷ 500 ±0.50
							foro/alb H9 - h9
							sm. e raggi 0.5
Ap.	Data	Dis.	descrizione modifica		N° DISEGNO		C.2380.EX
			peso kg. 2.02		disegnato		foglio 1
			Data 14.03.2024		GT		di 1
			Scala 1:1		CELLA DI CARICO A PERNO mod. PRX 50 KN/3 ASSIEME ATEX		controllato
MATERIALE			GREZZO		 METIOR s.r.l.		
TRATTAMENTO			FINITURA LAVORAZ.				
PROPRIETA' METIOR srl VIETATA LA RIPRODUZIONE ANCHE PARZIALE SENZA PREVA AUTORIZZAZIONE							